

Accessory rail for tableside mounted equipment

312/DS-099 - Multi-purpose spacer rail

Supplied with:

1 off 25 mm x 10 mm x 65 cm long integrated accessory rail (fitted)

1 off 28.6 mm x 9.5 mm x 65 cm long integrated accessory rail

Multi-purpose accessory rail for attachment of tableside rail equipment
(for use with an extended lateral moving tabletop)

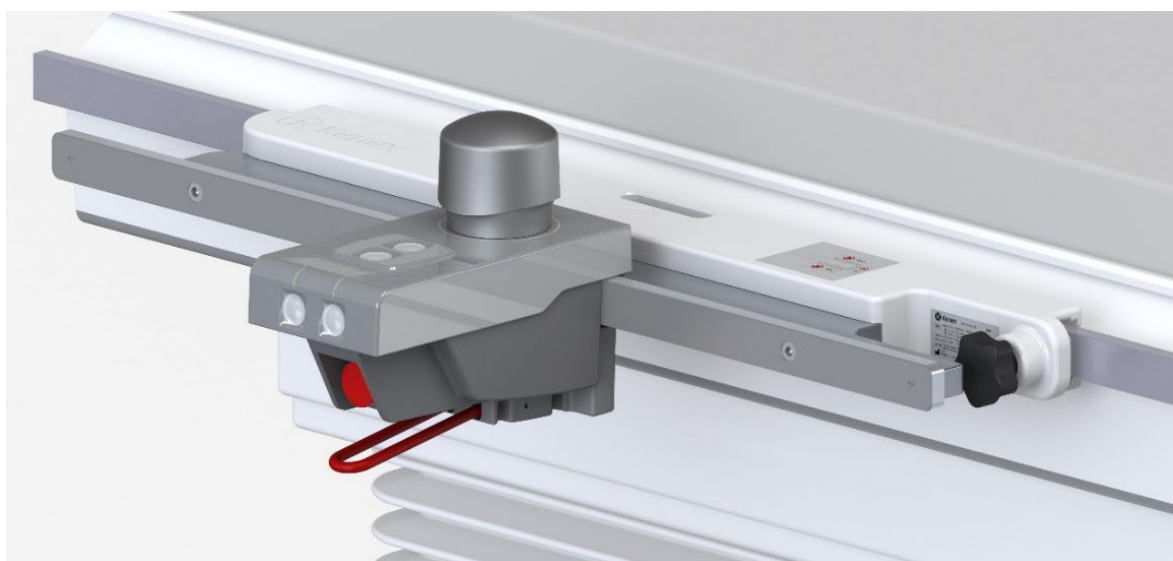

This multi-purpose accessory rail allows tableside mounted equipment to be used on a table featuring extended lateral tabletop movement. Rail accessories which would otherwise strike the table pedestal, are positioned outside of this movement range (see below). An attachment bracket slides onto a 25 mm high, or 28.6 mm high tableside accessory rail (maximum 11 mm thick). The securing handle position allows the shield to overhang the rail end and be repositioned further along the table if required.

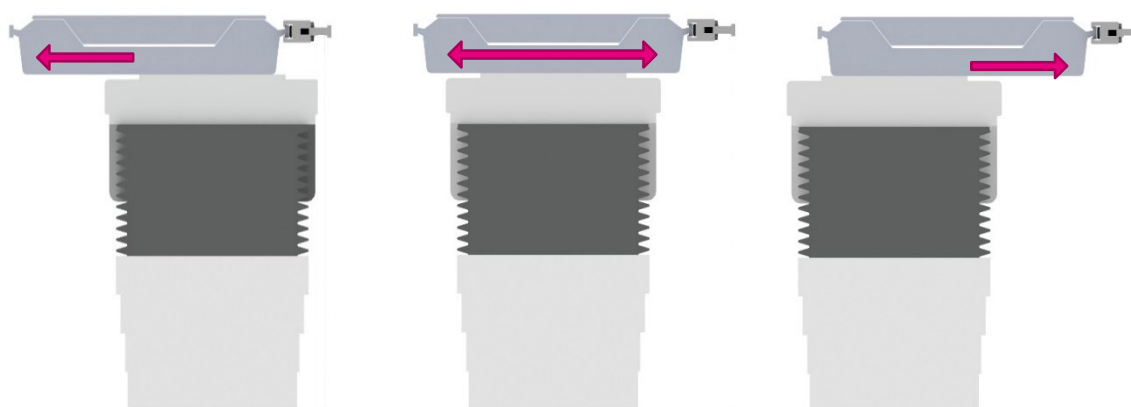



Weights and dimensions

Weights and dimensions are subject to manufacturing tolerance

312/DS-099:

Weight: **4.7 kg**

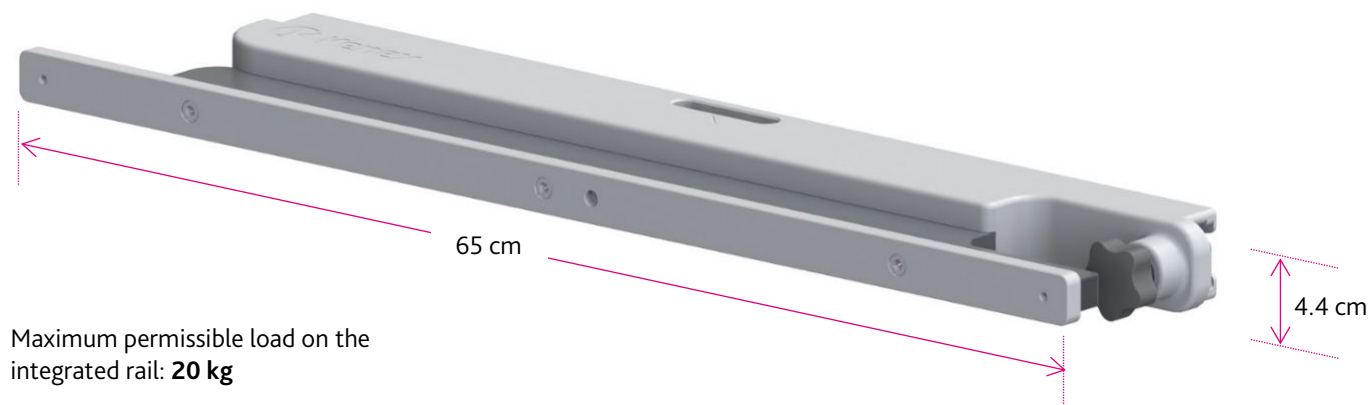

312/DS-099 attached to table rail - viewed from above

