



LED 300DF SC surgical lamp

340/631/03 (LED 300DF SC lamp with power supply, suspension arm and ceiling column)

Single colour surgical LED lamp

Facetted multi-lens system A multitude of computer-calculated facetted lenses guarantees homogeneity with minimal shadow in the light field. Separately arranged optical systems, with one LED module, generate their own light field, which increases the contrast effect of the OT-light.

Merging of the individual luminous fields By turning the sterilizable handle the LED-clusters with 12 lenses each, swivel. The single light fields can be joined and overlap to create one field with increased light intensity.

Focusing By turning the adjustment ring on the sterilizable handle the light field diameter, created by the single LED clusters can be varied. This allows a punctual illumination of the deepest wound channels with high intensity and exact matching of the light field diameter with the size of the surgical requirement.

Lamp features

- > Light intensity at 1 metre: 160,000 Lux
- > Step less dimming (28% to 100%) with on/off switch at lamp head
- > Colour rendering index R_a 96
- > Focusable light field size: 19 cm to 26 cm
- > Colour temperature: 4500 Kelvin
- > Temperature increase at head area: 0.5 °C
- > Total power consumption: max 89W
- > Light source: 36 LED's
- > Life span of over 60,000 hours
- > Diameter of lamp head: 55 cm
- > Detachable sterilizable handle included



Model 340/631/03 allows for versatile movement and is supplied with a two-part suspension arm and mounted onto an 80 cm ceiling column (other lengths available). The column can be attached to a load bearing or suspended ceiling (different installation aids are available to suit differing site conditions – see over). Alternatively, the column can be directly attached to the movable carriage of a 2.5 m or 4.2 m ceiling track (available separately) with lamp cables contained and managed within a separately supplied flexible energy chain. These options enable the complete assembly to move into and out of the working area as required. The spare pivot of the ceiling column can carry a Kenex radiation shield (available separately).



Technical specifications

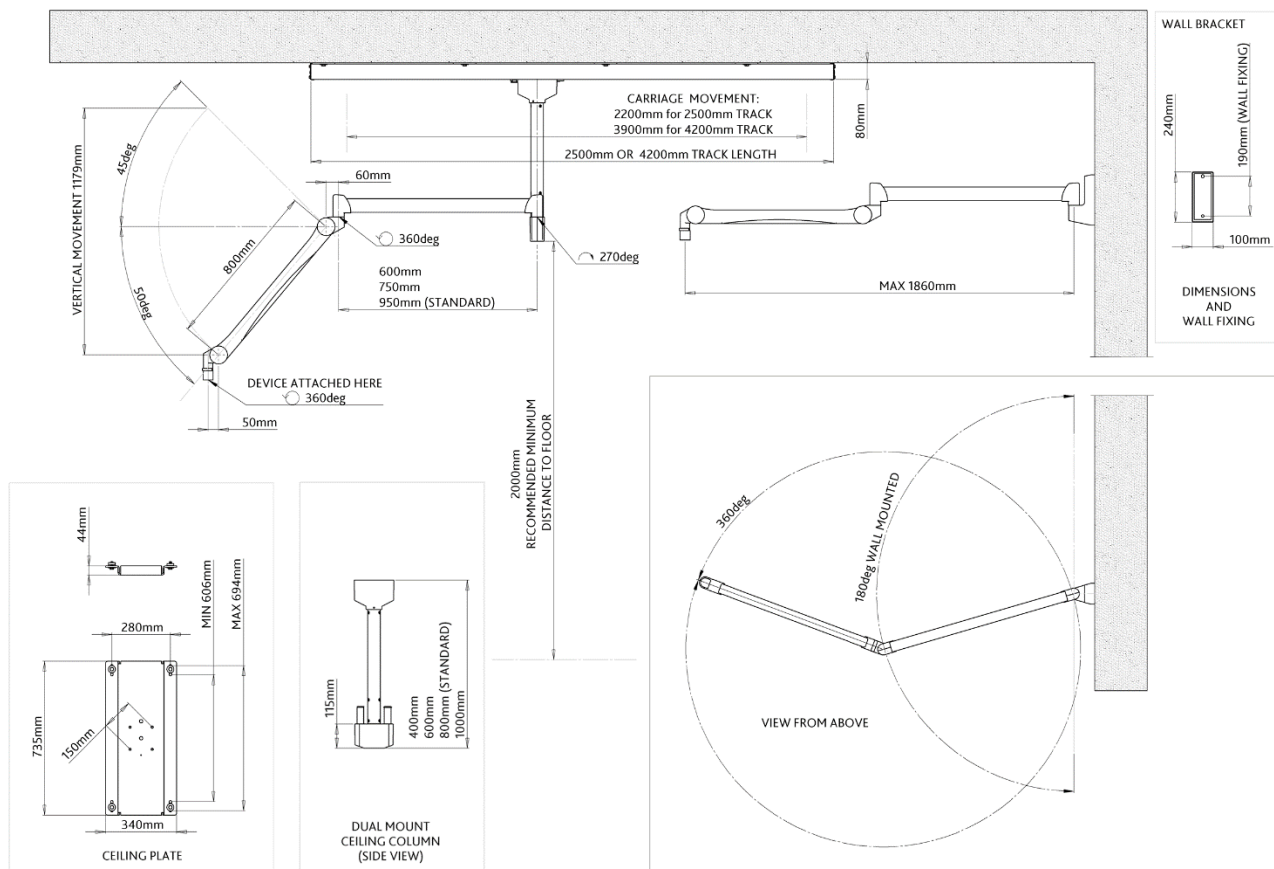

Equipment weights & part numbers

340/631/03

Power supply in housing

LED 300DF SC lamp head: **12 kg**

Suspension arm: **10.4 kg**

80 cm dual mount ceiling column: **12.5 kg**

Optional equipment:

Dual mount ceiling column:

- 40 cm (#300/COLUMN/40): **10 kg**
- 60 cm (#300/COLUMN/60): **11.2 kg**
- 100 cm (#300/COLUMN/100): **14.7 kg**

Ceiling track & carriage:

- 2.5 m (#3001/TC/250): **50 kg**
- 4.2 m (#3001/TC/420): **72 kg**

Track cable management:

- 2.5 m (#3001/TC/250/EC) **1.3 kg**
- 4.2 m (#3001/TC/420/EC) **1.7 kg**

Additional track carriage: For use in 2.5 m or 4.2 m track (#3001/3.25): **4.6 kg**

Installation aids: Ceiling mounting plate (#300/P/004) **14.8 kg**

Ceiling anchorage mount (#300/P/012) **37 kg**

Ceiling void installation (#300/P/014) **7.8 kg**

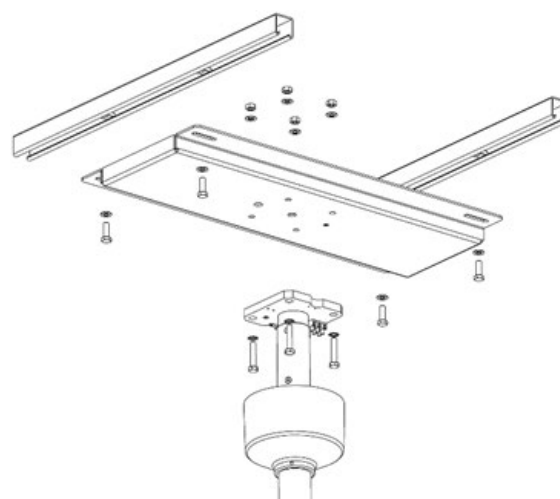

Ceiling mounting plate #300/P/004
(Shown with ceiling rails and ceiling column)