

Lower body x-ray shield

311/DS-020 (Philips Medical Systems part No. 9896-000-77201 & 9896-000-77202)

Table mounted shield (with fold down top shield)

This lower body shield reduces exposure to scatter radiation emanating from the table or patient's body. It comprises a lightweight and durable structure, with middle link and pivotal arm supporting a flexible lead curtain.

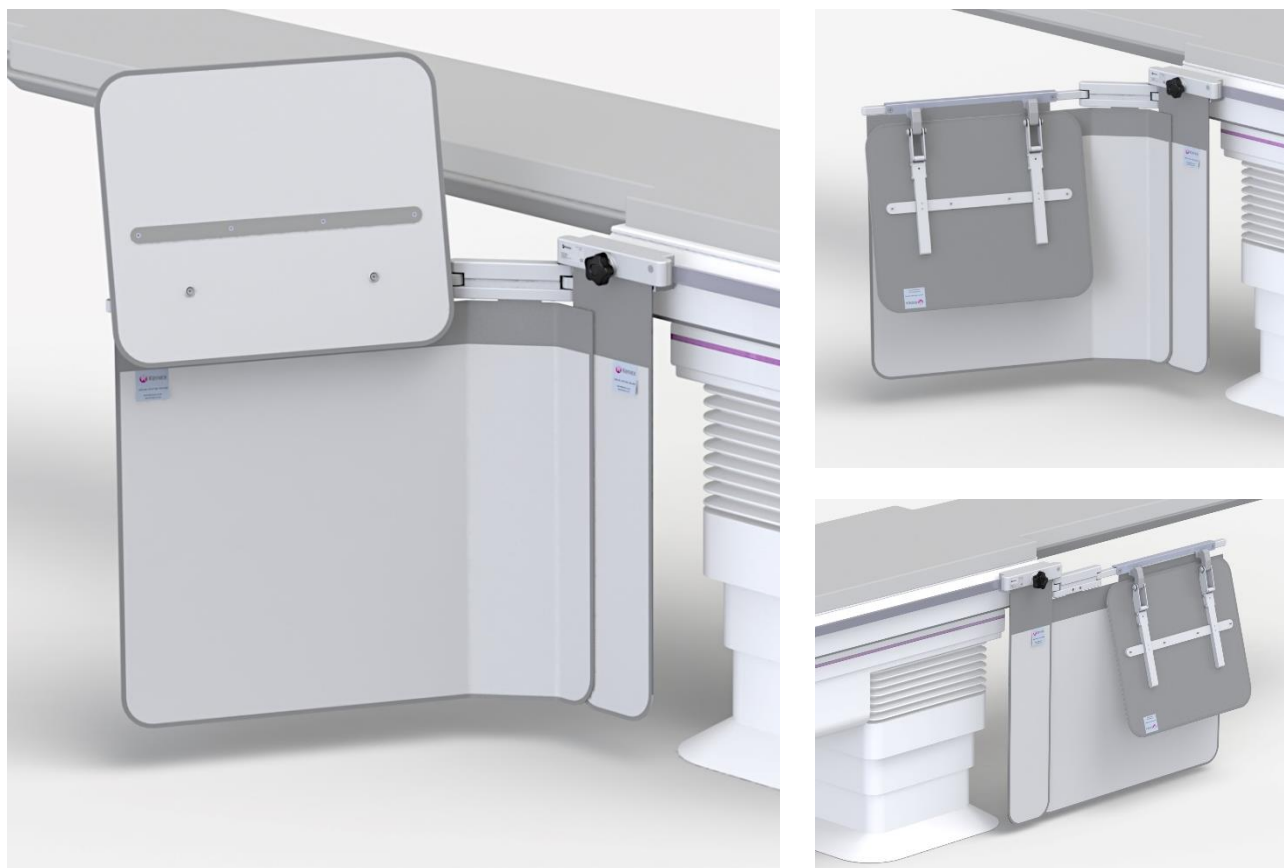

Features

- > The shield easily mounts to either side of the table allowing the pivotal arm to always face the head end.
- > The heavy duty middle link has an automatic wear adjustment facility ensuring accurate joint friction which prevents unwanted curtain movement even when the table is tilted in any direction.
- > A 52 cm wide top shield can be quickly folded downwards to ease patient transfer and access.
- > The pivotal arm and middle link can swivel outwards from the table side to form a 53 cm or 70 cm wing, or inwards to be positioned under the table when not in use.

Flexible x-ray protective curtain

- > The curtain measures 89 cm wide x 70 cm high providing a safe zone of occupancy for the Radiologist (or Cardiologist).
- > The curtain forms an under table x-ray tube without impeding movement.
- > The curtain's inner 0.5 mm lead equivalent layer is bonded to its outer covering. As the protective layer is not suspended separately in a cover (bag), it cannot tear or fall away inside unnoticed.

Weights, dimensions & ordering information

Weights and dimensions are subject to manufacturing tolerance

311/DS-020
Weight: 11 kg

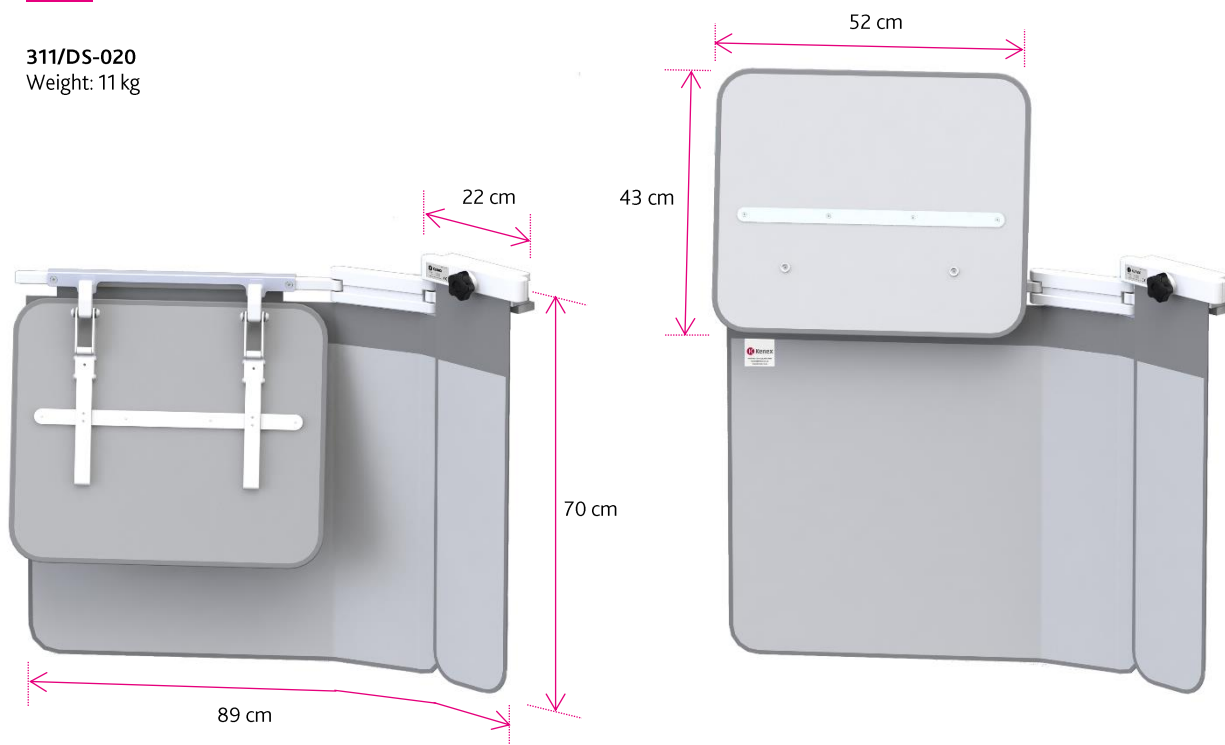

TIP

For continuity of protection, use the lower body shield with a Kenex overhead suspended see-through upper body shield.